



# AIRSHARK™

## Compact Rotary Material Separator

The AES AirShark™ is a robust, versatile rotary material separator with high air handling capacity and a compact footprint designed for both indoor and outdoor applications. An alternative to traditional screen separators and cyclones, the AirShark™ is a simple and effective way to separate material waste and manufacturing byproducts from the airstream.

### Features & Benefits

- Compact, modular design – installs above or below the roof
- V-apex rotor design for strength and durability
- Durable, heavy-gauge stainless steel screen
- Integrated rotary airlock with replaceable airlock seals
- Ideal replacement for cyclones and traditional screen separators
- High air handling capacity, up to 64,000 CFM
- No adjusting required for different material types
- Operates under positive or negative pressure
- Low power consumption for energy savings
- Only separator of its kind made in the USA



UP TO 64,000  
CFM CAPACITY



SMALL  
FOOTPRINT



LOW ENERGY  
CONSUMPTION



LONG  
SERVICE LIFE

## Uses and Applications

### Corrugated Box / Folding Carton:

Scrap removal systems

### Commercial Printing and Packaging:

Paper trim and die-cutter scrap

### EV Battery

#### Manufacturing:

Anode and Cathode Film Waste Capture and Recycling

### Nonwovens:

Light fraction and films

### Material Recycling Facility (MRF):

Plastic bag capture, light fractions, and film

### Manufacturing:

Ingredient bag capture and packaging waste



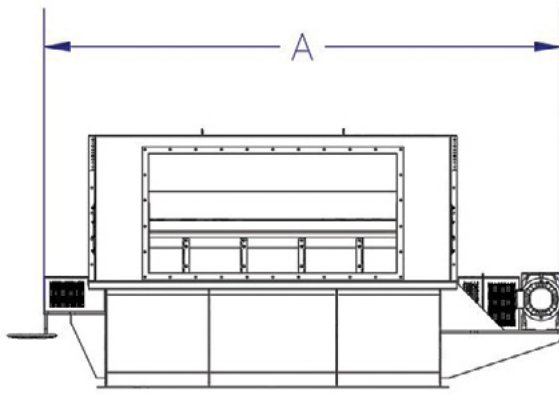

FRONT VIEW

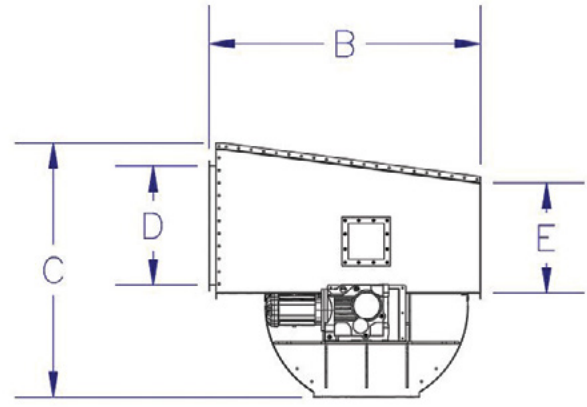

SIDE VIEW

## Specifications

Model	AS-10	AS-20	AS-32	AS-48	AS-64
CFM	10,000	20,000	32,000	48,000	64,000
Motor Size	2 HP	5 HP	5 HP	7.5 HP	7.5 HP
Inlet Dim.	19" x 20"	16" x 28"	58" x 28"	75" x 28"	90" x 28"
Outlet Dim.	36" x 19"	45" x 26"	83" x 26"	104" x 26"	119" x 26"
A	65"	83"	121"	142"	157"
B	48"	64"	64"	64"	64"
CFM	44"	59"	59"	59"	59"
D	20"	28"	28"	28"	28"
E	19"	26"	26"	26"	26"
Weight	1,500 lbs	2,700 lbs	3,200 lbs	3,900	4,600 lbs



# SOLVE YOUR SCRAP CONVEYANCE PROBLEMS.

**REQUEST MORE INFORMATION ABOUT THE AIRSHARK™ TODAY.**

(800) 572-9998 | [INFO@AESALES.NET](mailto:INFO@AESALES.NET) | [AESALES.NET](http://AESALES.NET)  
 535 HAGEY ROAD, SOUDERTON, PA 18964